

Aviaid  
10041 Canoga Ave.  
Chatsworth, CA 9131

818-998-8991

contact: **John Schwarz**

## *Aviaid Series 2 Dry Sump Pumps Boost Scavenging*

While Aviaid's original design Series 1 pumps have been continually refined since their introduction some 50+ years ago and proven a reliable "workhorse," the need to increase scavenging while maintaining tight space limitations has led to the development of the Stage 2 pumps.

The increased efficiency comes with employing Roots-style impellers in the scavenge sections instead of gears. The supercharger-like rotors create more vacuum, enabling the use of shorter sections if so desired (available with 1.000", 1.250", 1.500" and 1.750" sections). In addition to evacuating the oil pan, sections can be employed to purge the valve cover area of unnecessary oil, etc. A cast iron pressure section is standard in the same sizes.

Mounting blades are available to integrate Aviaid's Series 2 pumps into virtually any application. Cam-drive and accessory drive installations are also available. Pumps are available with 4 or more sections. All are manufactured in-house in Aviaid's California facility.

Founded in 1961, Aviaid is credited with introducing commercially available dry sump systems into motorsports over five decades ago and continues to be at the forefront of technology. For details visit [www.Aviaid.com](http://www.Aviaid.com), or call 818-998-8991 for personalized technical assistance.

*January, 2022*  
**FOR IMMEDIATE RELEASE**

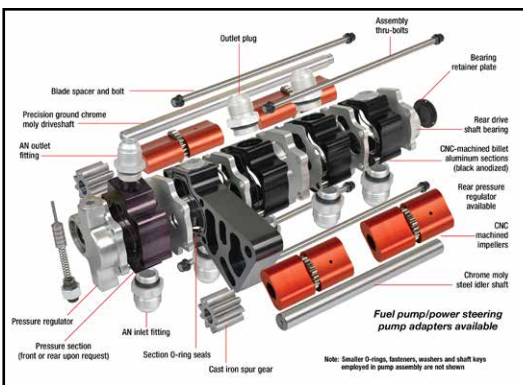

<https://electronic-pr.com/2022/01/aviaid-series-2-dry-ump-pumps-boost-scavenging/>



prepared by:  
**HOLLAND COMMUNICATIONS**  
9322 Crebs Ave.  
Northridge, CA 91324  
**818-854-6136**

#1205-381