

Aviaid
10041 Canoga Ave.
Chatsworth, CA 9131

818-998-8991

contact: **John Schwarz**

Aviaid Enhances Its Series 2 Pump Line

August, 2023
FOR IMMEDIATE RELEASE

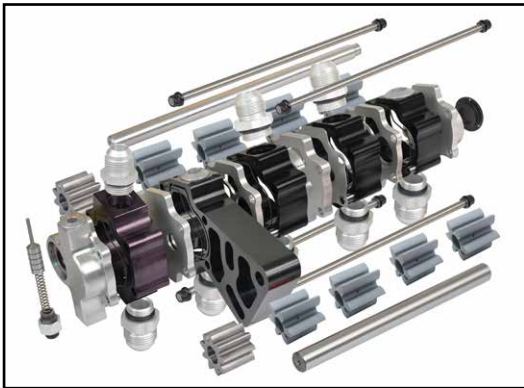

<https://electronic-pr.com/2023/08/series-2-pump-line/>

Aviaid Oil Systems, the company credited with pioneering dry sump oil systems in automotive competition back in the 1960s, has announced an upgrade to the firm's Series 2 oil pumps. A newly-developed 6-tooth gear design has proven to increase scavenging through-put some 12% over previous rotor designs. Now in its fourth iteration, all previous Series 2 models can be upgraded to the new design, if so desired.

Company president John Schwarz said, "Engine builders want to have increased vacuum in a compact pump package, so we've introduced this enhanced second generation Series 2 pump. With four available scavenge section widths ranging from 1.000" to 1.750" to choose from, plus 4, 5 and 6-stage designs, we can tailor scavenging vacuum to the engine builder's needs."

On the pressure side of the pump there are six different section widths available that range from .600" to 1.750". The unique design of the Series 2 pump allows the use of both standard and specially angled sections to facilitate running lines in very space-restricted installations. A variety of regulator sections and pump ends — as well as mounts — are employed to configure the pump to most any application.

Founded in 1961, Aviaid remains at the forefront of lubrication systems technology. The the company continues to manufacture its familiar Series 1 pumps, plus oil pans, dry sump tanks, remote filter adapters, and a variety of mounts that can accommodate virtually any 4, 6, 8, 10 or 12-cylinder engine. For details visit www.Aviaid.com or call 818-998-8991.